

CROWN

ESR 1000 SERIES

Specifications

Reach Truck



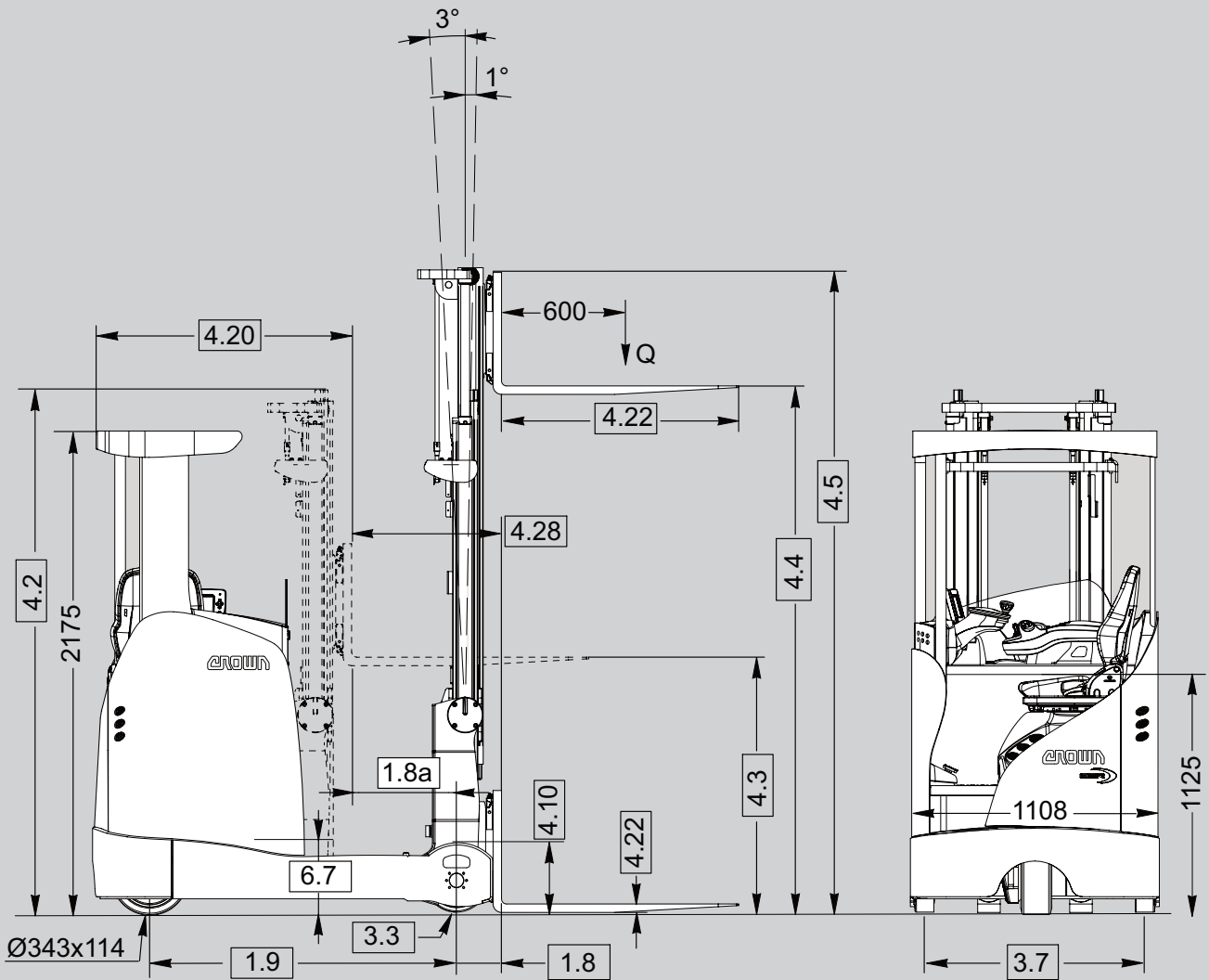
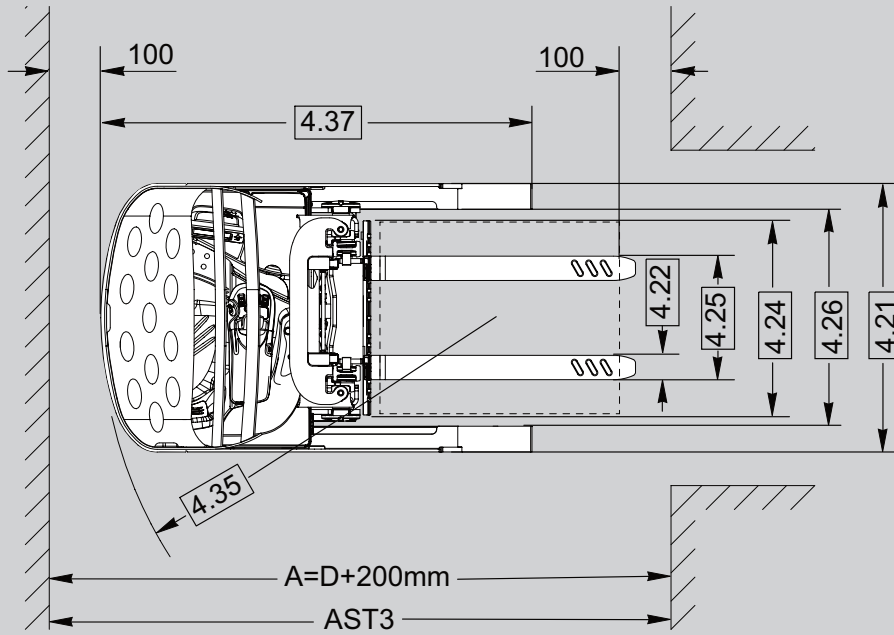

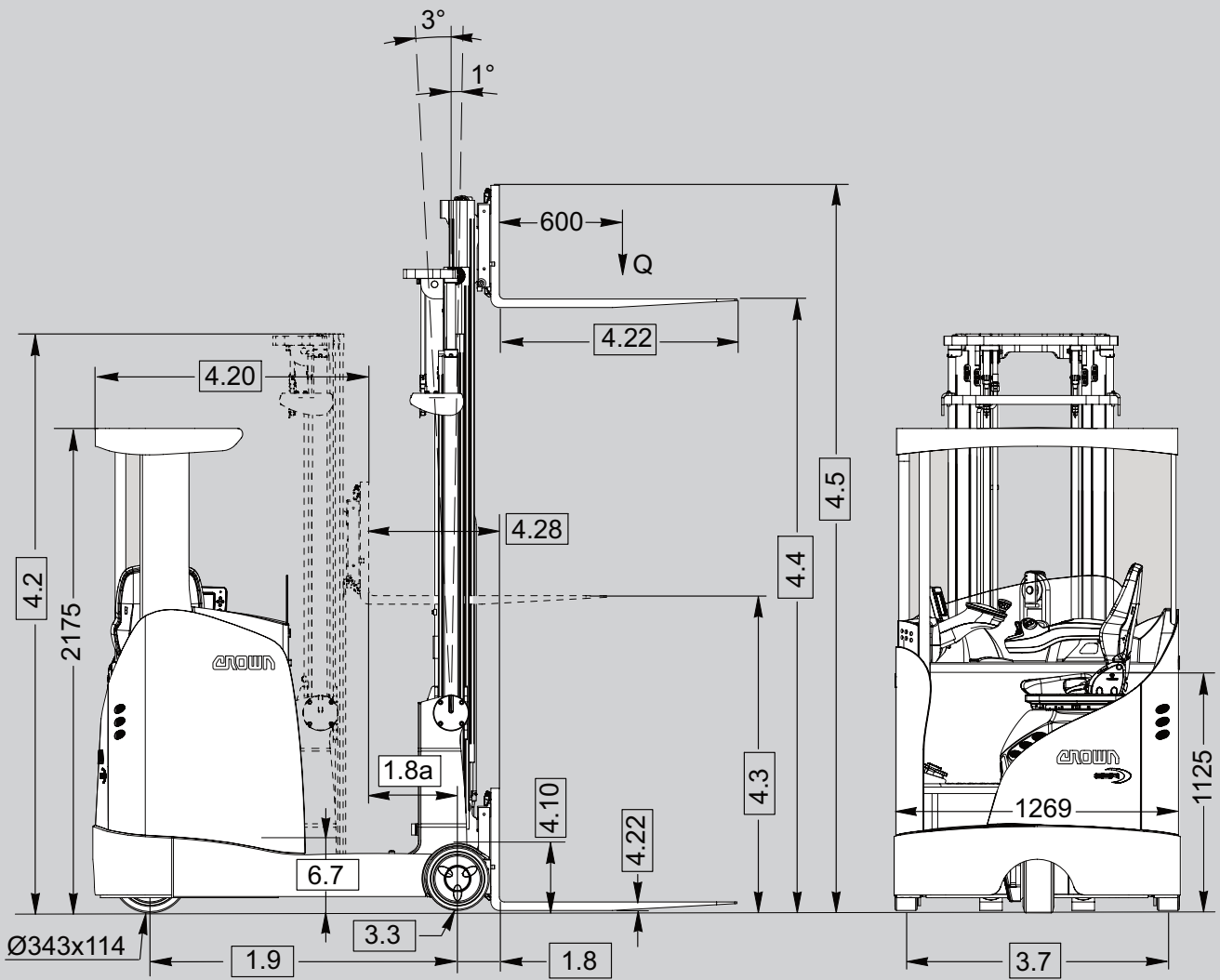
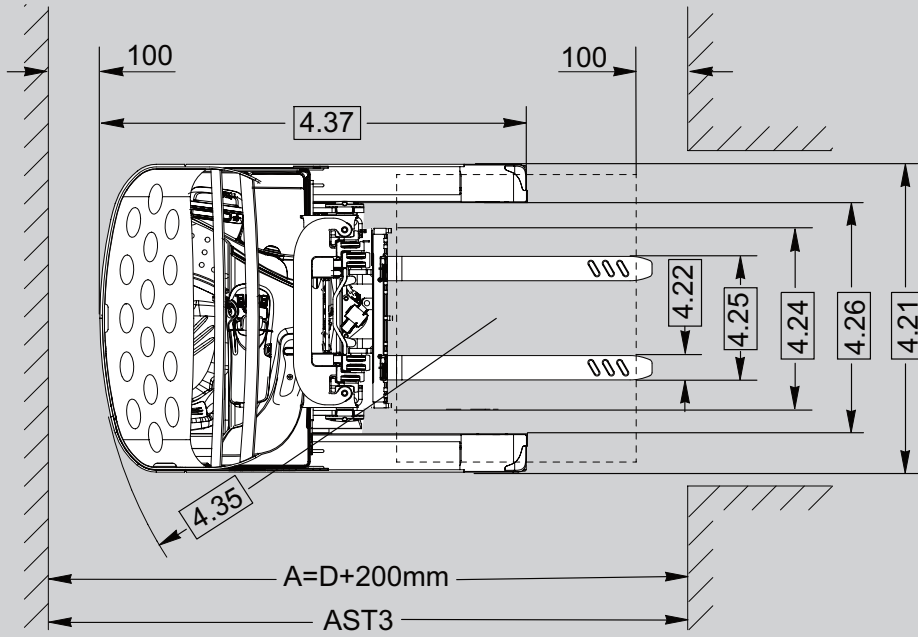

General Information	1.1	Manufacturer	Crown Equipment Corporation							
	1.2	Model			ESR 1020-1.4	ESR 1020-1.6	ESR 1040-1.4	ESR 1040-1.6		
	1.3	Power	electric							
	1.4	Operator Type	sit down							
	1.5	Load Capacity	Q	t	1.4	1.6	1.4	1.6		
	1.6	Load Centre	c	mm	600					
	1.8	Load Distance	mast extended	x	mm	202		187		
	1.8a		mast retracted	x1	mm	see table of dimensions 6		see table of dimensions 7		
	1.9	Wheel Base	y	mm	1380	1475	1380	1475		
Weights	2.1	Weight	less battery		kg	1855 [▲]		2055 ^{▲▲}		
	2.4	Axle Load	reach extended		kg	see table of dimensions 3				
	2.5		reach retracted		kg	see table of dimensions 3				
Tyres	3.1	Tyre Type	D/L							
	3.2	Tyres	front		mm	343 x 114				
	3.3		rear		mm	285 x 80		285 x 100		
	3.5	Wheels	no. (x=driven) front/rear				1x / 2			
	3.7	Track Width	rear	b11	mm	see table of dimensions 2				
Dimensions	4.1	Tilt	forward / backward	angle	°	see table of dimensions 4				
	4.2	Mast	collapsed height	h1	mm	see table of dimensions 4				
	4.3	Free Lift	w.o. load backrest	h2	mm	see table of dimensions 4				
	4.4	Lift Height		h3	mm	see table of dimensions 4				
	4.5	Mast	extended height, w.o. lbr	h4	mm	see table of dimensions 4				
	4.7	Overhead Guard Height		h6	mm	2175				
	4.8	Seat Height	compressed	h7	mm	1125				
	4.10	Outrigger Height			mm	312		301		
	4.15	Lowered Fork Height		h13	mm	38	45	38	45	
	4.16	Head Room	overhead guard		mm	1034				
	4.20	Headlength		l2	mm	see table of dimensions 6		see table of dimensions 7		
	4.21	Overall Width		b1/b2	mm	1120		1285		
	4.22	Fork Dimension		th	mm	38	45	38	45	
				wxl	mm	102 x 1145				
	4.23	Fork Carriage	ISO class		mm	2 A				
	4.24	Fork Carriage Width	with sideshift	b3	mm	770				
	4.25	Width Across Forks		b5	mm	see table of dimensions 2				
4.26	Inside Straddle		b4	mm	see table of dimensions 2					
4.28	Reach		l4	mm	see table of dimensions 6		see table of dimensions 7			
4.32	Ground Clearance	centre wheelbase	m2	mm	76					
4.33	Working Aisle Width	1000x1200 travers	Ast	mm	see table of dimensions 6		see table of dimensions 7			
4.34		800x1200 length	Ast	mm	see table of dimensions 6		see table of dimensions 7			
4.35	Turning Radius		Wa	mm	1638	1733	1645	1740		
4.37	Length Over Outriggers		l7	mm	1800	1895	1785	1880		
Performance	5.1	Travel Speed *	w. / w.o. load		km/h	10.0 / 10.0				
	5.2	Lift Speed	w. / w.o. load		m/s	0.4 / 0.6				
	5.3	Lower Speed	w. / w.o. load		m/s	0.5 / 0.5				
	5.4	Reach Speed	w. / w.o. load		m/s	0.18 / 0.18				
	5.7	Max. Gradeability	w. / w.o. load		%	12 / 12				
	5.10	Service Brake	regenerative, electric / load wheel brake				regen. / no	regen. / 1x	regen. / no	regen. / 1x
Motors	6.1	Traction Motor	60 min. rating		kW	9				
	6.2	Lift Motor	15% on time		kW	7.9				
	6.3	Max. Battery Box Size		lxhwx	mm	see table of dimensions 1				
	6.4	Battery Voltage	nominal capacity 5 h rating		V/Ah	48 / see table of dimensions 1				
	6.5	Battery Weight			kg	see table of dimensions 1				
	6.7	Battery Tray Height	w. / w.o. rollers		mm	303 / 292				
	Misc.	8.1	Type of Controller	drive / lift / steer			transistor			
8.4		Noise Level			dB(A)	65				

▲ TL mast 2760 mm + option 5 battery

* 1 km/h less in fork direction

▲▲ TL mast 2760 mm + option 1 battery

Table 1 Battery

	Battery Type		DIN C				DIN B				Length	Height
			Option 1	Option 2	Option 3	Option 4	Option 5	Option 6	Option 7	Option 8		
6.4	Battery Capacity	Ah	420-465	560-620	700-775	840-930	280-310	420-465	560-620	700-775		
6.5	Battery Weight min.-max.	kg	713-838	892-1056	1063-1258	1241-1467	542-621	709-816	890-1027	1063-1202		
6.3	Battery Box Size		Width				Width					
	ESR 1020 – 1.4	mm	–	–	–	–	263	353	443	–	1035	784
	ESR 1020 – 1.6	mm	–	–	–	–	–	353	443	533		
	ESR 1040 – 1.4	mm	283	355	427	–	–	–	–	–	1223	784
	ESR 1040 – 1.6	mm	283	355	427	–	–	–	–	–		
	ESR 1060 – 1.4	mm	283	355	427	–	–	–	–	–		
	ESR 1060 – 1.6	mm	283	355	427	499	–	–	–	–		
	ESR 1060 – 2.0	mm	–	355	427	499	–	–	–	–		

Table 2 Chassis Frame

		ESR 1020 ESR 1040 ESR 1060		Standard	Standard	Option	Standard	Standard
					Standard			
3.7	Track width rear	b11	mm	985	1177	1146	1317	1476
4.21	Overall width rear – chassis bottom	b2	mm	1120	1285	1285	1425	1575
	Overall width rear – chassis middle section	b2	mm	1108	1269	1269	1269	1269
4.24	Fork Carriage	b3	mm	750	750	750	750	980
4.25	Width across forks, max.	b5	mm	695	695	695	695	925
4.26	Width inside straddle	b4	mm	905	965	1070	1105	1255
	Sideshift movement	left / right	mm	50	70	70	70	100

Table 3 Axle Load

					without load			with load		
			reach		front	rear	total	front	rear	total
ESR 1020-1.4 / 1.6 with battery option 5	7500 TT	2.4	extended	kg	1558	1442	3000	783	3617	4400
		2.5	retracted	kg	1882	1118		1626	2774	
ESR 1040-1.4 / 1.6 with battery option 1	7500 TT	2.4	extended	kg	1536	1664	3200	730	3870	4600
		2.5	retracted	kg	1930	1270		1596	3004	
ESR 1060-1.4 with battery option 1	6090 TT	2.4	extended	kg	1607	1796	3403	807	3996	4803
		2.5	retracted	kg	2164	1239		1941	2862	
ESR 1060-1.6 with battery option 3	7950 TT	2.4	extended	kg	1890	2103	3993	1037	4556	5593
		2.5	retracted	kg	2437	1556		2174	3419	
ESR 1060-2.0 with battery option 3	9155 TT	2.4	extended	kg	2150	2373	4523	1042	5481	6523
		2.5	retracted	kg	2660	1863		2043	4480	

front = drive wheel rear = load wheels

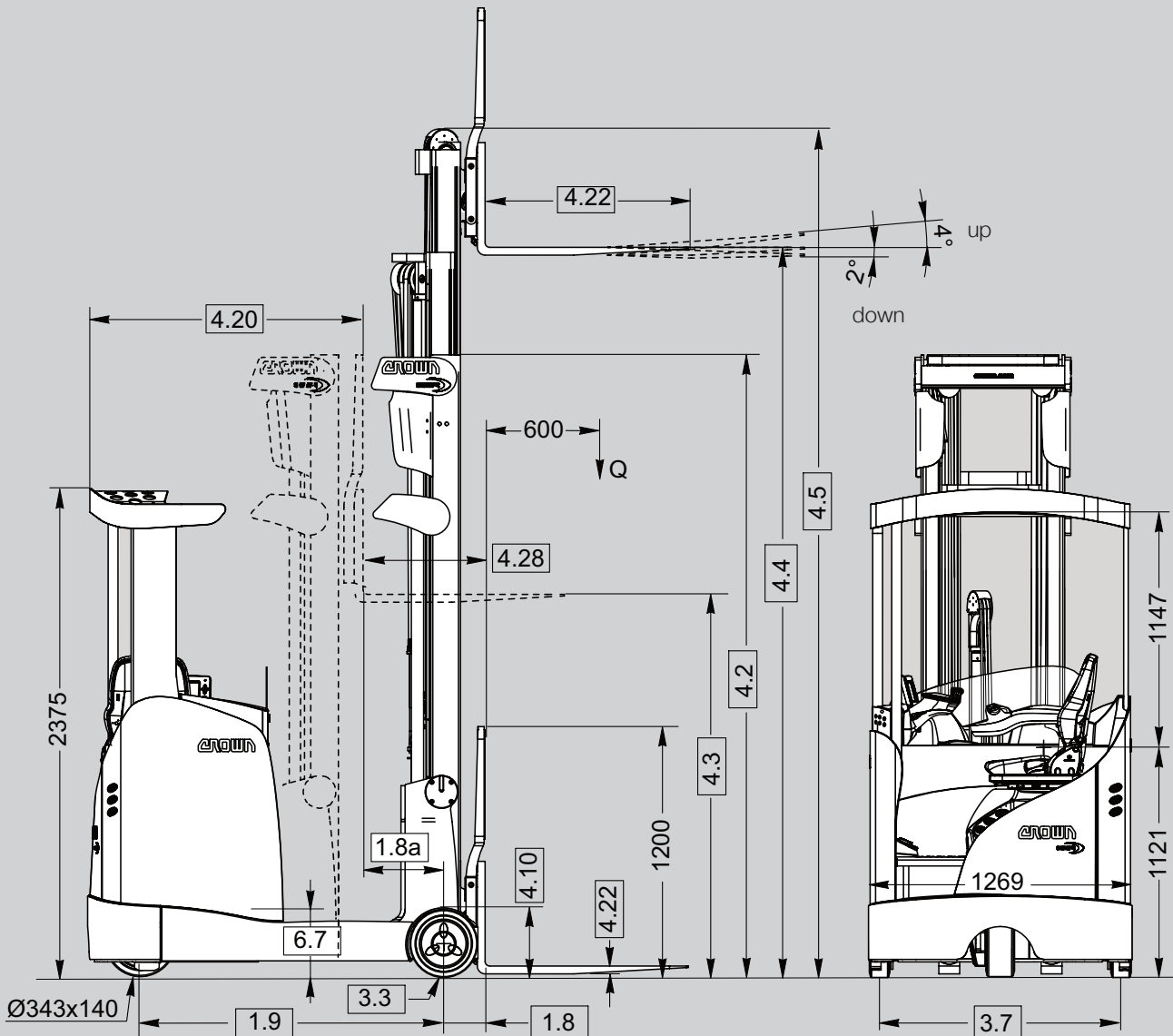
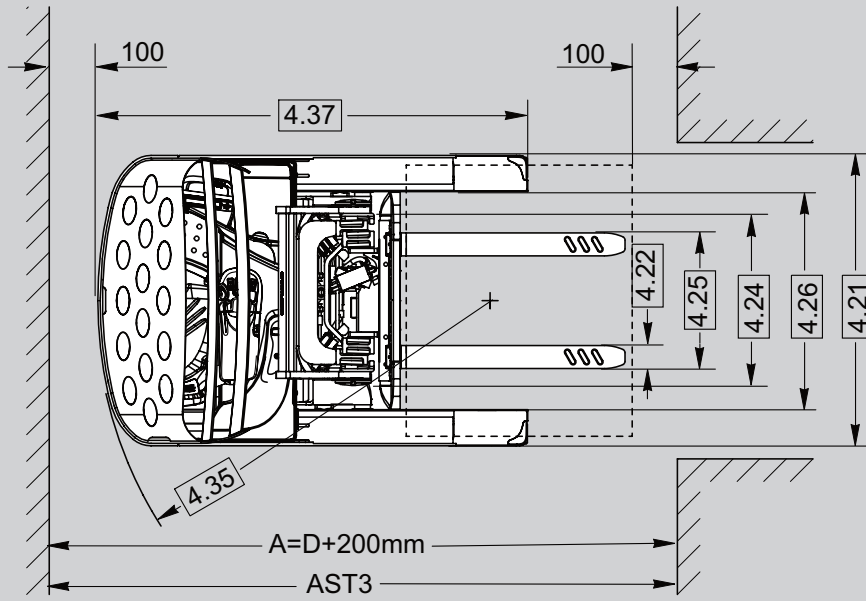

General Information	1.1	Manufacturer	Crown Equipment Corporation					
	1.2	Model			ESR 1060 - 1.4	ESR 1060 - 1.6	ESR 1060 - 2.0	
	1.3	Power	electric					
	1.4	Operator Type	sit down					
	1.5	Load Capacity		Q	t	1.4	1.6	2.0
	1.6	Load Centre		c	mm	600		
	1.8	Load Distance	mast extended	x	mm	187	217	217
	1.8a		mast retracted	x1	mm	see table of dimensions 8		
	1.9	Wheel Base		y	mm	1380	1475	1475
Weights	2.1	Weight	less battery		kg	2534 [▲]	2557 [▲]	2661 ^{▲▲}
	2.4	Axle Load	reach extended		kg	see table of dimensions 3		
	2.5		reach retracted		kg	see table of dimensions 3		
Tyres	3.1	Tyre Type	D/L					
	3.2	Tyres	front		mm	343 x 140		
	3.3		rear		mm	285 x 100	330 x 100	330 x 100
	3.5	Wheels	no. (x=driven) front/rear					
	3.7	Track Width	rear	b11	mm	see table of dimensions 2		
Dimensions	4.1	Fork Carriage Tilt	forward / backward	angle	°	2 / 4		
	4.2	Mast	collapsed height	h1	mm	see table of dimensions 5		
	4.3	Free Lift *	w.o. load backrest	h2	mm	see table of dimensions 5		
	4.4	Lift Height		h3	mm	see table of dimensions 5		
	4.5	Mast **	extended height, w.o. lbr	h4	mm	see table of dimensions 5		
	4.7	Overhead Guard Height	low / standard / angled	h6	mm	2175 / 2375 / 2554		
	4.8	Seat Height	compressed	h7	mm	1113		
	4.10	Outrigger Height			mm	301	346	346
	4.15	Lowered Fork Height		h13	mm	38	45	45
	4.16	Head Room	overhead guard		mm	1021		
	4.20	Headlength		l2	mm	see table of dimensions 8		
	4.21	Overall Width	front / rear	b1/b2	mm	see table of dimensions 2		
	4.22	Fork Dimension		th	mm	38	45	45
				wxl	mm	102 x 1145		
	4.23	Fork Carriage	ISO class		mm	2 A		
	4.24	Fork Carriage Width	w. lbr / w.o. lbr	b3	mm	770 / 750		
	4.25	Width Across Forks		b5	mm	see table of dimensions 2		
	4.26	Inside Straddle		b4	mm	see table of dimensions 2		
	4.28	Reach		l4	mm	see table of dimensions 8		
	4.32	Ground Clearance	centre wheelbase	m2	mm	76		
4.33	Working Aisle Width	1000x1200 travers	Ast	mm	see table of dimensions 8			
4.34		800x1200 length	Ast	mm	see table of dimensions 8			
4.35	Turning Radius		Wa	mm	1645	1734	1734	
4.37	Length Over Outriggers		l7	mm	1785	1903	1903	
Performance	5.1	Travel Speed	w. / w.o. load		km/h	14.0 / 14.0		
	5.2	Lift Speed	with 1000 kg / w.o. load		m/s	0.58 / 0.80	0.58 / 0.80	0.59 / 0.71
	5.3	Lower Speed	w. / w.o. load		m/s	0.57 / 0.57	0.57 / 0.57	0.57 / 0.50
		Xpress Lower Speed	w. / w.o. load		m/s	1.1 / 1.1		
	5.4	Reach Speed	w. / w.o. load		m/s	0.19 / 0.19		
	5.7	Max. Gradeability	w. / w.o. load		%	12 / 12		
5.10	Service Brake	regenerative, electric / load wheel brakes						
					regen / 2x			
Motors	6.1	Traction Motor	60 min. rating		kW	9		
	6.2	Lift Motor	15% on time		kW	16.5		
	6.3	Max. Battery Box Size		lxhwx	mm	see table of dimensions 1		
	6.4	Battery Voltage	nominal capacity 5 h rating		V/Ah	48 / see table of dimensions 1		
	6.5	Battery Weight			kg	see table of dimensions 1		
	6.7	Battery Tray Height	w. / w.o. rollers		mm	303 / 292		
	Misc.	8.1	Type of Controller	drive / lift / steer				
8.2		Available Working Pressure for Attachments						
8.4		Noise Level			dB(A)	210		
					65			

▲ 4890 mm + option 1 battery

* with load backrest 1.4 / 1.6 t -650 mm; 2.0 t -535 mm

▲▲ 4595 mm + option 2 battery

** with load backrest 1.4 / 1.6 t +650 mm; 2.0 t +535 mm

Table 4 Mast Chart ESR 1020 / ESR 1040

Mast				4.4 LIFT	4.2 CLSD	4.3 FREE	4.5 EXTD	4.1 TILT			
								ESR 1020-1.4 ESR 1040-1.4		ESR 1020-1.6 ESR 1040-1.6	
								h3	h1	h2	h4
Tilting Mast	Standard Duty	TL	mm	2760	1990	100	3305	2°	4°	0,5°	3°
			mm	3070	2150		3620				
			mm	3490	2360		4045				
			mm	3810	2520		4360				
			mm	4080	2650		4630				
			mm	4480	2850		5030				
			mm	4710	2970		5260				
			mm	4950	3090		5500				
	mm	5250	3240	5800							
	TT	mm	4210	1935	1415*	4740	1°	3°	0,5°	3°	
		mm	4680	2090	1570*	5210					
		mm	5315	2305	1785*	5850					
		mm	5790	2465	1945*	6325					
		mm	6190	2595	2075*	6725					
		mm	6795	2795	2275*	7320					
		mm	7140	2915	2395*	7675					
mm		7500	3030	2515*	8035						
mm	7700	3235	2710*	8235							
Tilting Carriage	Standard Duty	TT	mm	7950	3190	2515	8525	2°	4°	2°	4°
			mm	8415	3350	2670	8990				
			mm	8850	3490	2815	9425				
			mm	9090	3570	2900	9665				
			mm	9450 †	3690	3015	10025				

† ESR 1040 only

* Freelif h2 with sideshift: -100 mm

Extended height h4 with sideshift: +15 mm

Table 5 Mast Chart ESR 1060 (*Xpress Lower)

Mast			4.4 LIFT	4.2 CLSD	4.3 FREE	4.5 EXTD	ESR 1060 - 1.4	ESR 1060-1.6	ESR 1060-2.0
TT			h3	h1	h2	h4			
4-Roller Tilting Carriage	Heavy Duty	mm	4440	2020	1345	5015	●	●	-
		mm	4890	2170	1495	5465	●	●	-
		mm	5340	2320	1645	5915	●	●	-
		mm	5790	2470	1795	6365	●	●	-
		mm	6090	2570	1895	6665	●	●	-
		mm	6690	2770	2095	7265	●	●	-
		mm	7140	2920	2245	7715	●	●	-
		mm	7500	3040	2365	8075	●	●	-
		mm	7950	3190	2515	8525	●	●	-
		mm	8415	3345	2670	8990	○	○	-
		mm	8850	3490	2815	9425	○	○	-
		mm	9090	3570	2895	9665	○	○	-
		mm	9450	3690	3015	10025	○	○	-
		mm	9900	3840	3170	10475	-	○	-
		mm	10230	3950	3280	10805	-	○	-
		mm	10500	4040	3365	11070	-	○	-
mm	10700	4205	3535	11270	-	○	-		
mm	10835	4250	3580	11405	-	○	-		
mm	11045	4320	3650	11615	-	○	-		
6-Roller Tilting Carriage	Super Duty	mm	10835	4250	3580	11460	-	○	-
		mm	11045	4320	3650	11670	-	○	-
		mm	11435	4450	3780	12060	-	○	-
6-Roller Tilting Carriage	Heavy Duty	mm	4145	2020	1350	4770	-	-	●
		mm	4595	2170	1500	5220	-	-	●
		mm	5495	2470	1800	6120	-	-	●
		mm	6395	2770	2100	7020	-	-	●
		mm	6845	2920	2250	7470	-	-	●
		mm	7205	3040	2370	7830	-	-	●
		mm	8120	3345	2675	8745	-	-	●
		mm	9155	3690	3020	9780	-	-	●
		mm	9605	3840	3170	10230	-	-	●
		mm	9935	3950	3280	10560	-	-	●
	Super Duty	mm	10835	4250	3580	11460	-	-	●
		mm	11435	4450	3780	12060	-	-	●
		mm	12010	4640	3970	12635	-	-	●
		mm	9935	4420	3750	10560	-	-	●
		mm	10835	4720	4050	11460	-	-	●
		mm	11435	4920	4250	12060	-	-	●
mm	12000	5110	4435	12620	-	-	●		
mm	12600	5310	4635	13220	-	-	●		
mm	13000	5445	4770	13625	-	-	●		
mm	13560	5630	4960	14185	-	-	●		

* ESR 1060 Xpress Lower clsd h1 & free lift h2 add 80 ± 5 mm and extd h4 add max. 90 mm

● = available

○ = option 1 battery compartment not available

Table 6 Aisle Width ESR 1020

Pallet Size		ESR 1020			1.8a		4.20		4.28		4.33			
		Truck Configuration			Load Distance		Head length		Reach		Aisle Width		Add dimension	
Pallet	Length x Width	Capacity	Battery Size DIN 43531B	Mast	X1		L2		L4		AST3		Integrated Sideshift 1.4	Triplex Mast TT
	mm	Ah		Type	mm	mm	mm	mm	mm	mm	mm	mm		
Euro	800 x 1200	280 - 310	Option 5	TL	472	-	1166	-	674	-	2522	-	17	14
		420 - 465	Option 6	TL	387	482	1251	1251	589	684	2567	2612		
		560 - 620	Option 7	TL	297	392	1341	1341	499	594	2621	2659		
		700 - 775	Option 8	TL	-	302	-	1431	-	504	-	2713		
Euro	1200 x 800	280 - 310	Option 5	TL	472	-	1166	-	674	-	2669	-	26	22
		420 - 465	Option 6	TL	387	482	1251	1251	589	684	2745	2755		
		560 - 620	Option 7	TL	297	392	1341	1341	499	594	2826	2835		
		700 - 775	Option 8	TL	-	302	-	1431	-	504	-	2917		
BSI	1000 x 1200	280 - 310	Option 5	TL	472	-	1166	-	674	-	2638	-	21	17
		420 - 465	Option 6	TL	387	482	1251	1251	589	684	2696	2726		
		560 - 620	Option 7	TL	297	392	1341	1341	499	594	2763	2788		
		700 - 775	Option 8	TL	-	302	-	1431	-	504	-	2854		
BSI	1200 x 1000	280 - 310	Option 5	TL	472	-	1166	-	674	-	2722	-	25	21
		420 - 465	Option 6	TL	387	482	1251	1251	589	684	2793	2808		
		560 - 620	Option 7	TL	297	392	1341	1341	499	594	2871	2884		
		700 - 775	Option 8	TL	-	302	-	1431	-	504	-	2961		
Australian	1165 x 1165	280 - 310	Option 5	TL	472	-	1166	-	674	-	2744	-	23	19
		420 - 465	Option 6	TL	387	482	1251	1251	589	684	2810	2831		
		560 - 620	Option 7	TL	297	392	1341	1341	499	594	2884	2901		
		700 - 775	Option 8	TL	-	302	-	1431	-	504	-	2975		
Asian	1200 x 1200	280 - 310	Option 5	TL	472	-	1166	-	674	-	2782	-	23	19
		420 - 465	Option 6	TL	387	482	1251	1251	589	684	2849	2869		
		560 - 620	Option 7	TL	297	392	1341	1341	499	594	2923	2940		
		700 - 775	Option 8	TL	-	302	-	1431	-	504	-	3013		
GMA 40" x 48"	1219 x 1016	280 - 310	Option 5	TL	472	-	1166	-	674	-	2742	-	25	21
		420 - 465	Option 6	TL	387	482	1251	1251	589	684	2813	2829		
		560 - 620	Option 7	TL	297	392	1341	1341	499	594	2891	2904		
		700 - 775	Option 8	TL	-	302	-	1431	-	504	-	2982		

Table 7 Aisle Width ESR 1040

Pallet Size		ESR 1040			1.8a		4.20	4.28		4.33			
		Truck Configuration			Load Distance		Head length	Reach		Aisle Width		Add dimension for	
Pallet	Length x Width	Capacity	Battery Size DIN 43531C	Mast	X1		L2	L4		AST3		Integrated Sideshift 1.4	Triplex Mast
	mm	Ah		Type	mm	mm	mm	mm	mm	mm	mm		
Euro	800 x 1200	420 - 465	Option 1	TL	452	547	1186	639	734	2539	2591	16	12
		560 - 620	Option 2	TL	385	480	1253	572	667	2575	2620		
		700 - 775	Option 3	TL	315	410	1323	503	598	2617	2656		
Euro	1200 x 800	420 - 465	Option 1	TL	452	547	1186	639	734	2694	2706	26	21
		560 - 620	Option 2	TL	385	480	1253	572	667	2753	2764		
		700 - 775	Option 3	TL	315	410	1323	503	598	2816	2825		
BSI	1000 x 1200	420 - 465	Option 1	TL	452	547	1186	639	734	2658	2692	20	16
		560 - 620	Option 2	TL	385	480	1253	572	667	2705	2734		
		700 - 775	Option 3	TL	315	410	1323	503	598	2756	2781		
BSI	1200 x 1000	420 - 465	Option 1	TL	452	547	1186	639	734	2745	2763	24	20
		560 - 620	Option 2	TL	385	480	1253	572	667	2802	2817		
		700 - 775	Option 3	TL	315	410	1323	503	598	2861	2875		
Australian	1165 x 1165	420 - 465	Option 1	TL	452	547	1186	639	734	2766	2790	23	19
		560 - 620	Option 2	TL	385	480	1253	572	667	2819	2840		
		700 - 775	Option 3	TL	315	410	1323	503	598	2875	2894		
Asian	1200 x 1200	420 - 465	Option 1	TL	452	547	1186	639	734	2804	2827	23	19
		560 - 620	Option 2	TL	385	480	1253	572	667	2857	2878		
		700 - 775	Option 3	TL	315	410	1323	503	598	2914	2932		
GMA 40" x 48"	1219 x 1016	420 - 465	Option 1	TL	452	547	1186	639	734	2765	2783	24	20
		560 - 620	Option 2	TL	385	480	1253	572	667	2822	2837		
		700 - 775	Option 3	TL	315	410	1323	503	598	2882	2895		

Table 8 Aisle Width **ESR 1060**

ESR 1060		6.4 Battery	4.20 Headlength	1.8a Load Distance	4.28 Reach	4.33 & 4.34			
kg	Wa mm	Ah	l2 mm	x1 mm	l4 mm	Load Size length mm	width mm	Aisle Width VDI mm	
1400	1645	420 - 465	1281	357	544	800	1200	2591	
						1200	800	2778	
						1000	1200	2724	
		1200	1000	2825					
		560 - 620	1338	300	487	800	1200	2626	
						1200	800	2830	
	1000					1200	2767		
	700 - 775	1410	228	415	1200	1000	2875		
					800	1200	2674		
					1200	800	2896		
	1600	1734	420 - 465	1288	445	662	800	1200	2631
							1200	800	2788
1000							1200	2751	
1200			1000	2840					
560 - 620			1345	388	605	800	1200	2662	
						1200	800	2839	
		1000				1200	2791		
1200		1000	2888						
700 - 775		1417	316	533	800	1200	2705		
					1200	800	2904		
					1000	1200	2844		
1200		1000	2950						
840 - 930	1489	244=	461	800	1200	2752			
				1200	800	2970			
				1000	1200	2899			
1200	1000	3013							
2000	1734	560 - 620	1345	388	605	800	1200	2662	
						1200	800	2839	
						1000	1200	2791	
		1200	1000	2888					
		700 - 775	1417	316	533	800	1200	2705	
						1200	800	2904	
	1000					1200	2844		
	1200	1000	2950						
	840 - 930	1489	244	461	800	1200	2752		
					1200	800	2970		
					1000	1200	2899		
	1200	1000	3013						

Standard ● / Optional ○	ESR 1020	ESR 1040	ESR 1060
Truck Features			
1120 mm overall width	●		
1285 mm overall width		●	●
1425 mm overall width			○
1575 mm overall width			○
1400 kg lift capacity at 600 mm load centre	●	●	●
1600 kg lift capacity at 600 mm load centre	●	●	●
2000 kg lift capacity at 600 mm load centre			●
Battery Compartment			
48V 280-310 Ah	⑦		
48V 420-465 Ah	○	○	④
48V 560-620 Ah	○	○	○
48V 700-775 Ah	⑨	○	○
48V 840-930 Ah			⑤
Battery rollers for horizontal extraction	○	○	○
DIN 160 Rema connector	●	●	●
SBE 160 connector blue	○	○	○
SB 350 connector blue	○	○	○
Li-Ion ready	○	○	○
Controls and Instruments			
Gena operating system control	●	●	●
7" color touch screen display tiltable with navigation keypad	●	●	●
Display control via C-Drive	○	○	○
Keyless start-up with PIN code	○	○	○
Keyless start-up with Prox Reader (HID)	●	●	●
Key switch	○	○	○
Travel/steer direction indicator	●	●	●
Real-time clock and date	●	●	●
Battery discharge indicator with lift lockout	●	●	●
Hour meters for various system functions	●	●	●
Fingertip hydraulic controls	●	●	●
Dual lever hydraulic controls	○	○	○
Multi-task hydraulic controls	○	○	○
Driving Features			
Optimised Cornering Speed (OCS)	●	●	●
e-GEN braking system	●	●	●
OnTrac™ anti slip traction + brake	●	●	●
Loadwheel brake system	⑧	⑧	●
Ramp hold automatic braking for slopes + push-back rack	●	●	●
Electro-mechanical parking brake	●	●	●
Selectable performance levels (F1, F2, P1, P2, P3)	●	●	●
360 Select™ steering system + indicator	●	●	●
Lifting Features			
Patented offset mast design	●	●	●
Tilting duplex mast (TL)	○	○	
Tilting triplex mast (TT)	①	①	
Integrated sideshift for tilting masts	○	○	
Triplex mast (TT) with tilting fork carriage and sideshift	②	②	●
Patented Xpress Lower™ faster mast lowering speed incl. Regen Lower			○
Tilt and sideshift single activation	●	●	
Tilt Position Assist (TPA)	⑪	⑪	○
Lift height and load weight indicator	⑪	⑪	○
Free lift indicator	●	●	●
Auto Height Select (AHS)	⑪	⑪	○
Capacity Data Monitor (CDM)	⑪	⑪	○
Sideshift Position Assist (SPA)	⑪	⑪	○
Lift speed reduction before maximum height	●	●	●
Travel speed reduction above 1000 mm lift height	○	○	○
Travel speed reduction above free lift	●	●	●
No load on outrigger function + override switch	③	③	③
Five raise cutouts with override switch incl. zone select	○	○	○
Colour camera system (fork or mast mounted)	⑩	⑩	○
ISO class 2A fork carriage	●	●	●
Forktip indicators	●	●	●
4th hydraulic function	○	○	●

Standard ● / Optional ○	ESR 1020	ESR 1040	ESR 1060
Lifting Features			
5th hydraulic function			○
Load backrest	○	○	●
Operator Comfort			
Panorama Glass Overhead Guard		○	○
Patented high-visibility overhead guard	●	●	●
Plexiglass or mesh overhead guard cover	○	○	○
MSG 65 seat with adjustable lumbar support	○	○	●
FlexBack™ seat backrest			○
Suspension seat	●	●	○
Heated vinyl seat	○	○	○
Heated cloth seat	○	○	○
Headrest	○	○	○
Controls mounted on armrest	●	●	●
Armrest adjustable back + forth	⑫	●	●
Armrest adjustable back + forth + tiltable armrest pad	○	○	○
Adjustable steering column with tools	●	●	○
Adjustable steering column without tools	○	○	●
Automotive-type accelerator and brake pedals	●	●	●
Multiple storage areas for tools	●	●	●
Low, wide entry step	●	●	●
Desktop with clipboard	○	○	●
Safety Features			
Operator presence pedal	●	●	●
Seat switch	●	●	●
Power disconnect switch	●	●	●
Safety reminders	●	●	●
Work lights (halogen or LED)	○	○	○
Flashing light (strobe or LED)	○	○	○
Blue warning light	○	○	○
Audible travel alarm	○	○	○
Rearview mirror	○	○	○
Laser guidance system	○	○	○
Maintenance Features			
Event code history	●	●	●
Built-in diagnostic system	●	●	●
InfoPoint™ maps	●	●	●
Brushless AC motors	●	●	●
Swing-out seat deck for easy access	●	●	●
InfoLink® fleet management system, integrated	●	●	●
Work Assist® Accessories			
Clipboard	○	○	○
Scan gun holder	○	○	○
Adjustable arm for WMS monitor	○	○	○
12, 24 or 48V power supply	○	○	○
Reading light	○	○	○
Trash bin			○
Beverage holder	○	○	○
Storage pocket	○	○	○
USB-Port	○	○	○
Special Applications			
Drive-in rack overhead guard	○	○	○
Aisle guide rollers	○	○	○
Coldstore condition to -30°C	○	○	○
Coldstore cabin with environmental control			○
Narrow outriggers (1070 mm inside)			⑥
Load wheel protection		○	○

- ① Lift heights ≤ 7700 mm
- ② Lift heights > 7700 mm
- ③ Stops forks above outriggers if mast is retracted
- ④ Not with Coldstore Cabin
- ⑤ 1600 and 2000 kg only
- ⑥ All 1600 kg lift heights incl. SD-mast, not with 420-465 Ah battery
- ⑦ Available on ESR 1020-1.4
- ⑧ ESR 1020/1040 1.4 tilt mast no load wheel brake
- ⑨ Available on ESR 1020-1.6
- ⑩ Mast camera only above 6800 mm
- ⑪ Not applicable for tilt mast
- ⑫ ESR 1020 Armrest fixed

Operator Compartment and Controls

A comfortable low, wide step speeds entry. Non-slip floor mat ensures smooth and safe entry/exit. Once seated, the operator position can be adjusted to suit small and large operators.

A 17,8 cm (7") colour touchscreen delivers real-time information on the truck's operating status. Thirteen selectable widgets allow the operator to customise the display.

The travel direction switch, accessory controls, Auto Height Select and all hydraulic functions are at the operator's fingertip. Operators can manoeuvre the truck while blending lift and attachment functions to improve productivity.

The ergonomic armrest is wide and soft with fore and aft adjustment. There are five easily accessible storage compartments and an optional on-board USB-Port for charging mobile devices.

Gena operating system

Crown's next-generation truck operating system with integrated InfoLink provides optimum performance and makes vital information easy to see, understand and use for operators and technicians. It is an enhanced real-time truck management experience that gives you data-rich user experience and provides unmatched truck control for all primary truck systems:

- Traction motor control
- Hydraulic valve and motor control
- Steer & Brake motor control
- Programmable performance profiles
- Personalised information/ advanced diagnostic display/operator messaging
- Safety checklists and Dynamic Coaching

The Gena user experience is designed to let operators easily adapt the display for the specific task at hand. Screens also offer context-sensitive help including alerts, automated assistance, dynamic data and coaching.

The Crown display is used for easy trouble shooting, accessing service history and setting performance features. No handset or laptop required – all functions are on-board and easy to use.

Productivity Features

Speed up your productivity with optional Xpress Lower and Super Duty Mast. This exclusive technology lets you double lowering speeds, resulting in substantial savings in time and money.

Auto Height Select with one-touch control provides precision load stop at programmed rack heights. Tilt Position Assist with mast deflection compensation ensures the forks are level to the ground, regardless of load weight. Capacity Data Monitor provides visual indication and warning when limits are reached. Mast reach/retract speed adjusts depending on lift height and load for more confident handling.

Traction Control

OnTrac anti-slip traction control monitors truck dynamics, optimises tractive effort, reduces spinning during acceleration, prevents lock-up during braking, and can extend tire life. It increases traction performance in wet, dusty or freezer conditions.

Travel

Crown's AC traction system is a closed loop traction control system that maintains top speed throughout the battery charge. Engineered and manufactured by Crown, the AC motor, controller and drive unit are designed specifically for lift truck applications.

Crown's intelligent Optimised Cornering Speed recognises whether the operator is driving into or out of a curve, with the system analysing steer tyre angle, driving direction and steering direction. It then automatically adjusts speed and acceleration for maximum safe performance. Ramp Hold is an automatic braking function for slopes and push-back racks.

Hydraulic System

The control system for the hydraulic pump motor and proportional valves facilitates precise and sensitive execution of all hydraulic functions. All hydraulic parameters such as lift, lower, tilt, side shift, and reach speeds are fully adjustable and can therefore be adapted to different applications.

Moving Mast

Crown's unique offset, wide view mast delivers excellent visibility at height as well as for low-level operations. Mast cross-bracing and overhead guard bracing have been angled, and hose and chain rollers have been canted to further enhance visibility.

The ESR 1020 and 1040 features a range of duplex and triplex masts with limited or full free lift. Tilting masts can compensate for uneven floors common in wet and outdoor applications.

The ESR 1060 features heavy & super duty triplex masts with full free lift, integrated side shift and tilting fork carriage. Mast channels are reinforced to minimise static and dynamic deflection when storing heavy loads at tall lift heights.

Drive unit

A highly efficient drive unit with Rhein-tacho sensor, helical gearing, integrated pinion and vertically mounted 3-phase (AC) noise reduced traction motor provides silent, powerful traction performance. The large Vulkollan™ drive wheel offers high load capacity, long life, and excellent travel comfort.

Steering

360 Select™ control system allows the operator to choose between 180° and 360° steer tyre rotation to match driving conditions, experience level or personal preference. The system can be locked in either mode with password-protected access.

Braking

A disc brake on the motor armature shaft combined with motor regenerative e-GEN braking provides sure braking with fewer parts and maintenance requirements.

A foot pedal applies the service brake. The truck can also be brought to a stop by reversing the travel direction using the electric regenerative plugging function.

The parking brake is activated automatically when the truck comes to a stop. Once the operator has the feet on both pedals and selected the travel direction the parking brake will automatically be released.

Motors

The Crown manufactured 3-phase (AC) motors deliver high torque and seamless reversal. Traction and hydraulic motors are oversized for superior thermal capability and are especially suitable for high lift heights, high loads and high ambient temperature applications.

Safety Regulations

Conforms to European safety standards. Dimensions and performance data given may vary due to manufacturing tolerances. Performance is based on an average size vehicle and is affected by weight, condition of truck, how it is equipped and the conditions of the on-site operating area. Crown products and specifications are subject to change without notice.

Data Communication

The truck is fitted with a wireless data communications system that electronically collects truck and usage data (in particular hours of operation, battery charge level, status of certain parts that are subject to wear and tear, impacts etc.) and automatically transmits such data to Crown for service and maintenance purposes as well as for statistical analysis. Dealers have to inform their customers respectively.